



**PA System on the train**      12/19/24    (Train\_PA\_Description.pdf)

**Overview**

To operate the system, plug in the 12-volt battery pack to the system in the caboose, 308. The system runs autonomously!

The battery pack is charging on the desk in the yard office.

When the GPS receiver acquires lock to the satellites the system will beep three times.



At the end of the day, return the battery pack to the Yard Office and connect to the charger.

Make sure the **switch** is **ON**. It will not charge if the switch is off.

The system has been updated to run automatically. When the GPS receiver acquires lock to the satellites the system will beep. It will play sound tracks before the train has departed and provide information to our passengers about our railroad and museum as the train travels to New Hill. The microphone can be used for live announcements. The system has been installed in caboose 308.



## Details:



The system is powered by a 12-volt 20-amp hr. lithium battery. The battery feeds the amplifier and a buck regulator set to 5 volts to power the Raspberry Pi GPS system. Raspberry Pi audio output is fed to the AUX input of the mixer through a 2:1 isolation transformer which provides +6db of gain. The transformer also filters the power supply noise from getting into the audio.

The amplifier generates a 70 volt audio signal which is distributed to all of the passenger cars on the train.

Before the train leaves the station, the system plays four announcements at 15, 10, 5 and 1 minute prior to the scheduled departure time.



During the train ride, the system plays several audio announcements at points along the route based of the GPS coordinates of the train' position.

The audio file and the procedures for determining when they are played are stored in the Raspberry Pi computer.

The scheduled departure times are derived from the annual schedule of all of the train rides. The Despatcher's Report EXEL workbook, 2023 Trains, contains a workbook by the same name. This 2023 Trains workbook needs to be saved as a comma separated value file named schedule.csv.

The GPS coordinates used when the train is moving are derived from another EXEL file with the name **gps-data.csv**. This file contains the location latitudes, file names, directions and volume levels. For details on this part of the system see:

[https://wedcrew.yolasite.com/resources/GPS\\_system\\_Description.pdf](https://wedcrew.yolasite.com/resources/GPS_system_Description.pdf), appendix 13

## Hardware:

12-volt, 2 amp-hr. battery  
5-Volt Buck regulator with custom cables  
Audio Amplifier  
GPS receiver

Raspberry Pi computer  
Microphone  
Interconnection cables  
Audio isolation transformer with +6db gain

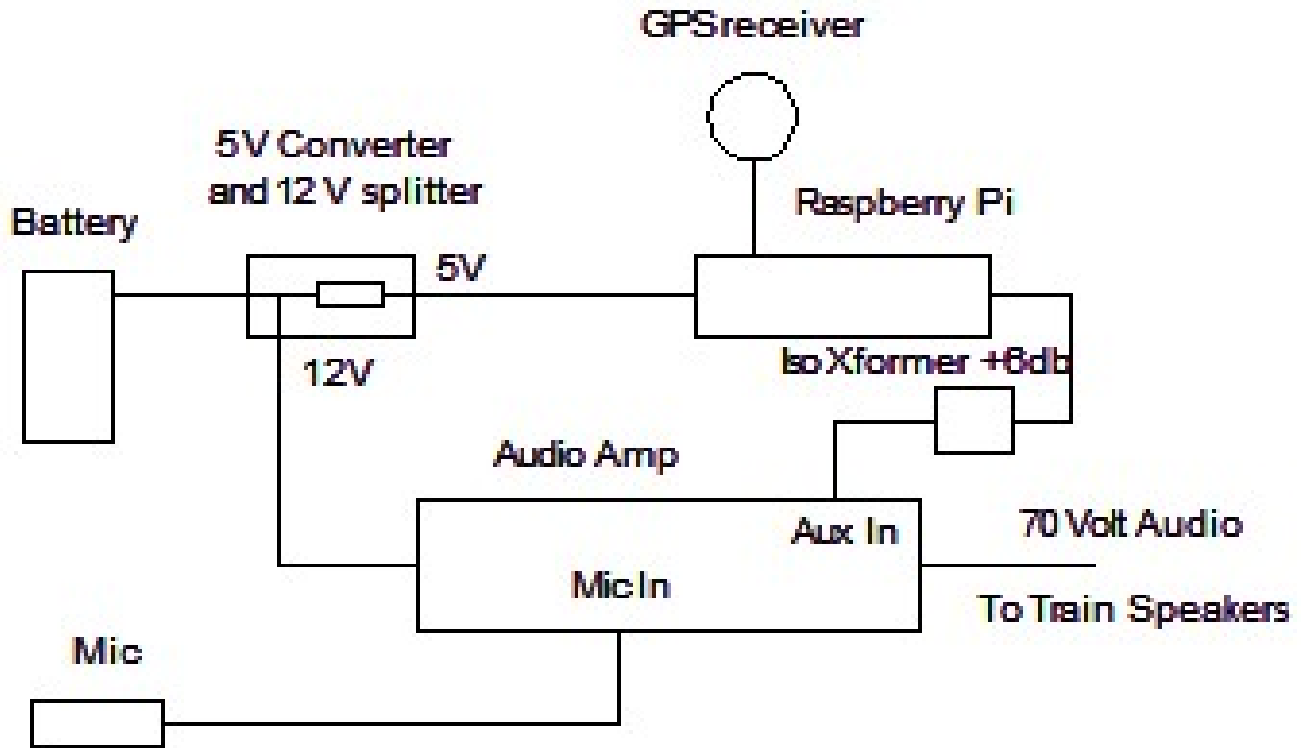

Block Diagram



Mic Level

Computer Level

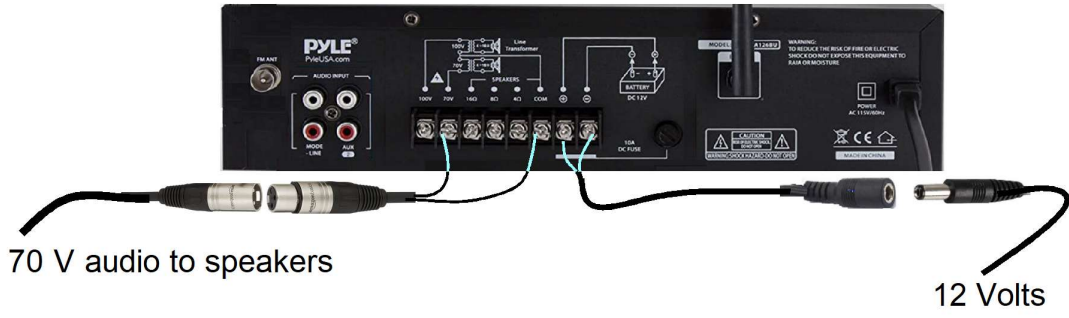

12 Volt splitter and 5 volt regulator

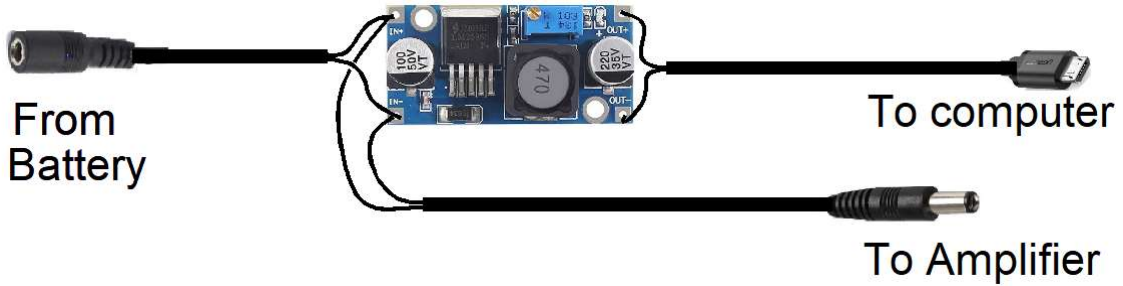

Isolation transformer with +6db gain

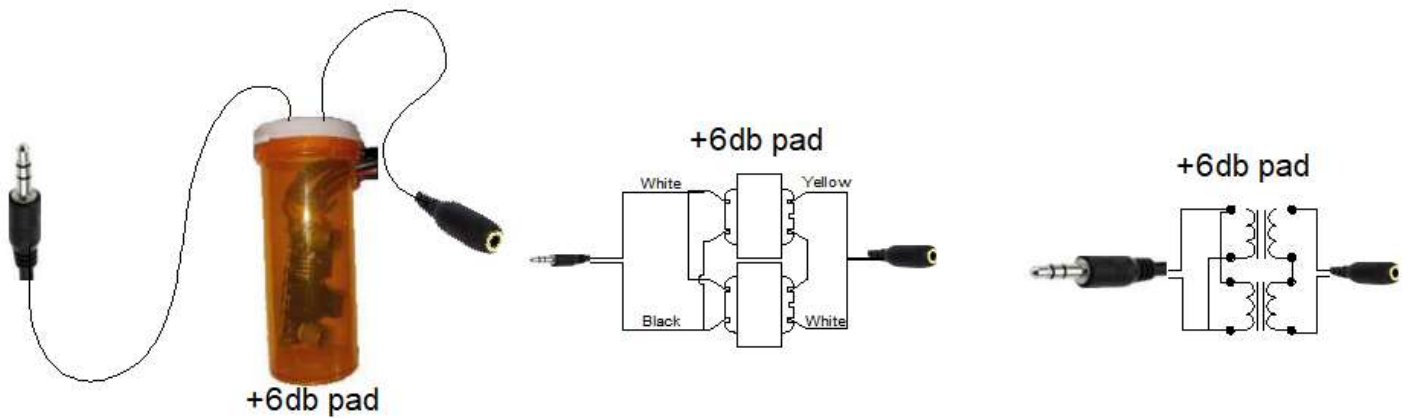

Obsolete Isolation Transformer

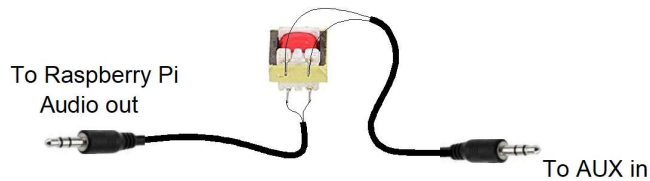



With a keyboard connected to the Raspberry Pi, the volume of the Background music and the Sound Effects can be adjusted using the Nine, Zero, Plus and Minus keys

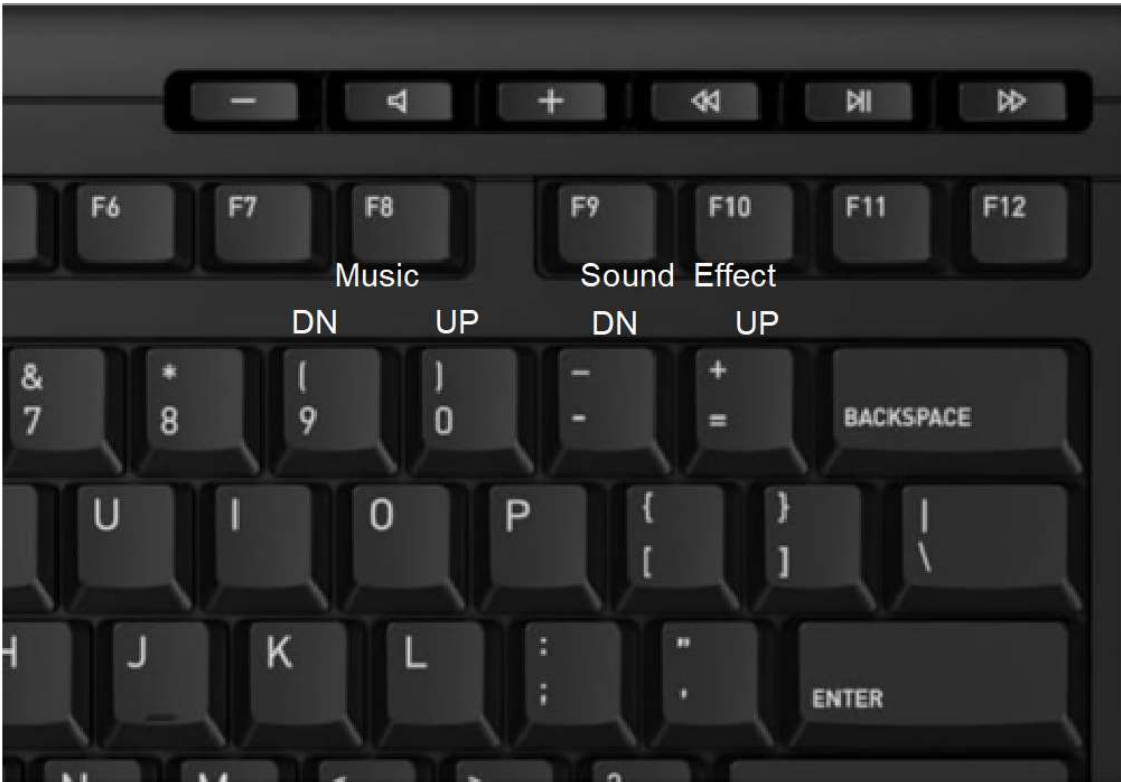



## Other Keyboard functions

From GPS System Description page 10.

### Ctrl-c operations

*Label:*

#### **ctrl-c functions**

**est dst tone1k tone**

**pre prevol nb sb music voice**

*The Ctrl-c performs the following functions:*

*Note: The ctrl-c stops the background audio track. To restart the track enter background.*

*The original purpose of the Ctrl-c function was to capture the latitude information rather than manually typing it in.*

*This function has been expanded.*

*This logging will work without a monitor connected to the Raspberry Pi.*

*Using the Ctrl-c function.*

*Press the **Ctrl** and the **c** keys. The LED will stop flashing and remain on.*

*If there is a background audio track running, the LED will continue to flash. Press the **Ctrl** and the **c** keys again and the LED will stop flashing and remain on.*

*Note: The first Ctrl-c will be detected by the mplayer program and will stop playing the background audio track. The next Ctrl-c will be detected by the operating program and will pause the system for the operator to enter the commands.*

*Operations after ctrl-c is pressed*

**est** Sets system time to eastern standard time

**dst** Set system time to eastern daylight saving time

**tone** Plays a 440 Hz tone for 20 minutes

**tone1k** Plays a 1000 Hz tone

**voice** Plays a voice track for 50 minutes

**pre** Plays the four audio tracks that will play before departure

**prevol** Allows user to change the volume of the four pre- departure audio tracks

**nb** Plays the north bound tracks

**sb** Plays the south bound clips

To stop playing these tracks, press the “q” key.

